

Roca

IN-WASH INSPIRA

A80306L009

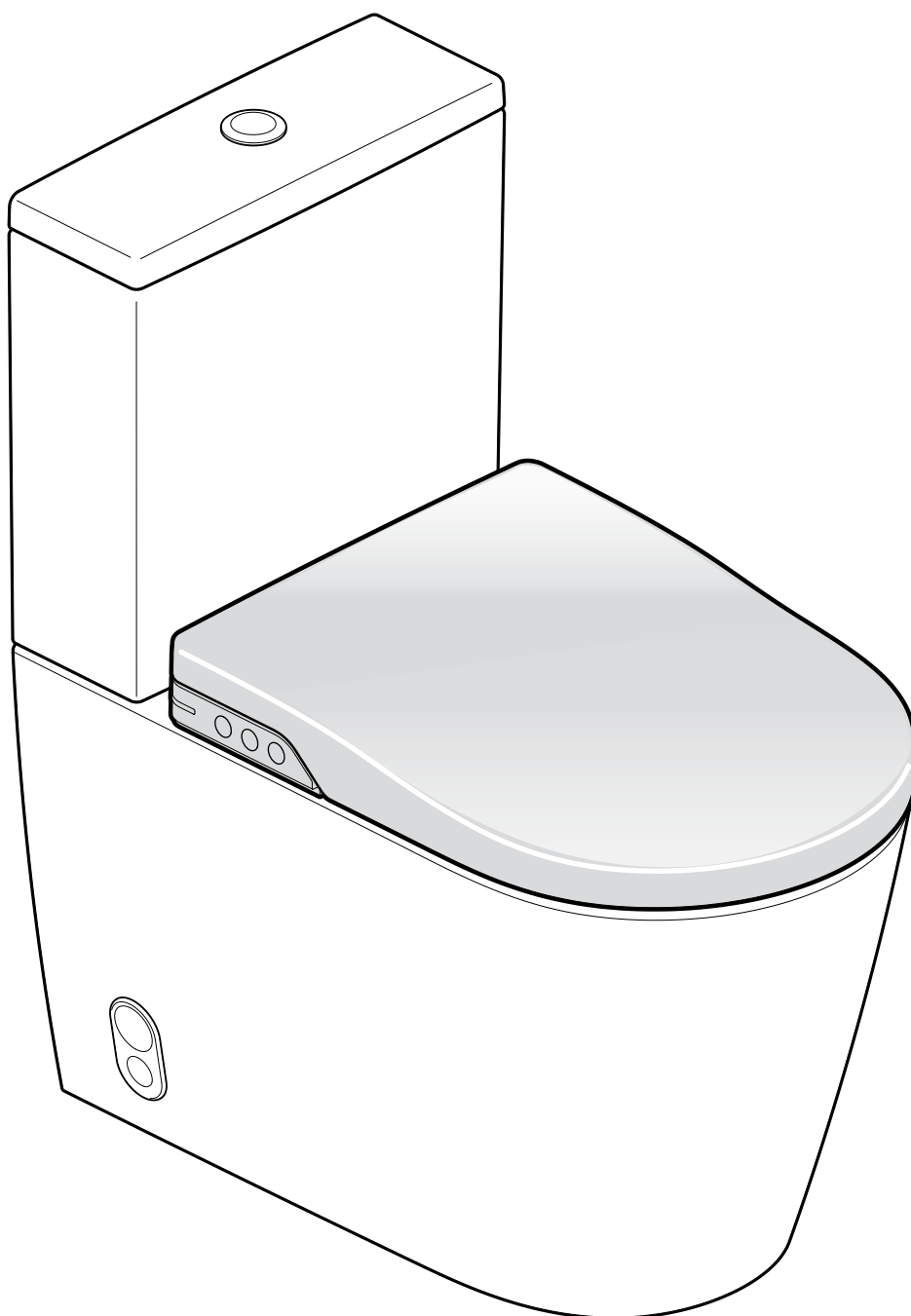

DE / FR / IT / EN

- DE** - Lesen Sie vor der Installation diese Montageanleitung und das beiliegende Blatt mit den Sicherheitshinweisen. Die Teile müssen gemäß der Anleitung installiert werden.
- Elektronische Anschlüsse dürfen nicht beschädigt werden.
 - Regenwasser oder Grauwasser bzw. voll entsalztes Wasser sind für den Betrieb nicht geeignet. Das In-Wash Dusch WC darf nur mit normalem Trinkwasser betrieben werden.
 - Der empfohlene Wasserdruck liegt zwischen 0.5 bar - 9 bar. Das Gerät im angegebenen Wasserdruckbereich verwenden.
 - Die Temperatur des Wasserzulaufs muss zwischen 10 und 30 °C betragen. Vergewissern Sie sich, dass die Wassertemperatur in diesem Bereich liegt.
 - Für die Installation nur den im Lieferumfang enthaltenen Wasserzulaufschlauch verwenden.
 - Vergewissern Sie sich, dass das Produkt ordnungsgemäß geerdet ist (ohne Erdung besteht das Risiko von Durchschlägen oder Kriechströmen, die zum Stromschlag führen können).
 - Sorgen Sie vor der Installation für einen geeigneten Stromanschluss gemäß den geltenden örtlichen Vorschriften.
-

- FR** - Avant l'installation, lire attentivement ce manuel d'installation et les consignes de sécurité. Les éléments doivent être installés selon ces instructions.
- Les eaux de pluie ou déminéralisées ainsi que l'eau de mer, l'eau industrielle ou les eaux usées ne sont pas adéquates pour l'utilisation de cet équipement. L'In-Wash doit travailler avec de l'eau potable du réseau.
 - Ne pas endommager les éléments de la connection électrique.
 - L'intervalle de pression de l'eau recommandé est 0.5 bar - 9 bar. Utiliser l'équipement avec l'intervalle de pression de l'eau recommandé.
 - La température de l'eau doit être comprise entre 10 et 30°C.
 - Ne pas utiliser un autre flexible que celui fournit avec le produit.
 - S'assurer que le produit est correctement connecté à une prise de terre. (Si le produit n'est pas connecté à une prise de terre, il y a un risque de rupture ou de fuite électrique qui pourrait entraîner un choc électrique).
 - Avant l'installation, s'assurer d'avoir une sortie électrique disponible adéquate, en accord avec les normes locales en vigueur.
-

- IT** Prima di procedere all'installazione, leggere attentamente questo manuale e le precauzioni riportate. sicurezza. I pezzi devono essere installati secondo le istruzioni.
- L'acqua piovana, l'acqua demineralizzata, l'acqua marina o le acqua grigie non sono adeguate per il funzionamento di questo apparecchio. Il vaso con funzione bidet In-Wash funziona solo con normale acqua potabile.
 - Non danneggiare i pezzi del collegamento elettrico.
 - Il range della pressione dell'acqua raccomandata è 0,05 MPa - 0,9 MPa. Utilizzando le attrezzature con queste raccomandazioni sulla pressione dell'acqua.
 - La temperatura dell'acqua deve essere compresa tra 10 - 30 ° C. Assicurarsi che la temperatura dell'acqua sia in questo intervallo.
 - Non usare un differente tubo di alimentazione rispetto a quello incluso nella confezione.
 - Assicurarsi che il prodotto sia elettricamente collegato correttamente a terra. (Senza messa a terra, vi è il rischio di rotture o dispersioni elettriche).
 - Disporre preventivamente di una presa elettrica secondo le normative correnti.
-
- EN** - Before installation, read thoroughly this installation manual and the included safety precautions leaf. Parts must be installed according to the instructions.
- Rain water, demineralized water, sea water or grey water are not suitable to operate this equipment. The In-Wash shower toilet may only be operated with normal drinking water.
 - Do not damage the electrical connection parts.
 - The recommended range of water pressure of the water supply is 0.5 bar - 9 bar. Use this equipment within the recommended water pressure range.
 - The temperature of the water supply must be between 10 - 30°C. Make sure the water temperature is between this range.
 - Do not use a water hose other than the one provided with this product.
 - Make sure that this product is correctly attached to a ground connection. (If the product is not ground-connected, there is a risk of a breaking or electric leak that might result in an electric shock).
 - Prior to the installation, have an adequate electrical outlet available, according to the current local legislation.
-

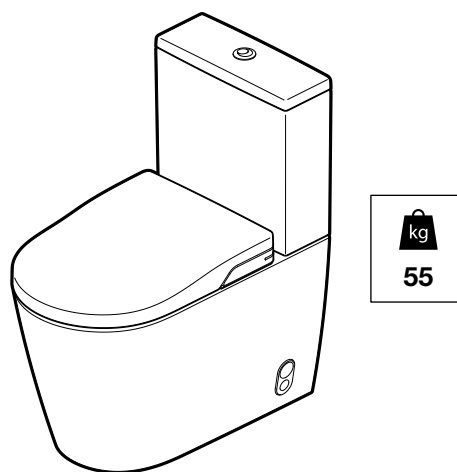
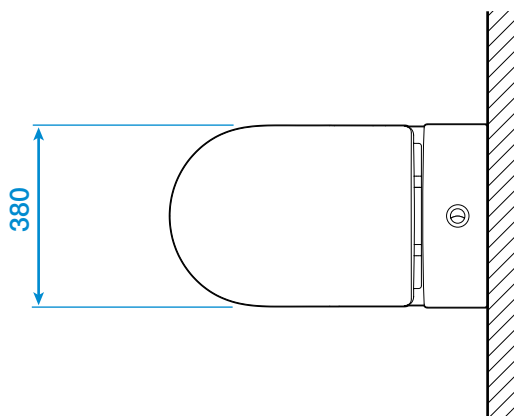
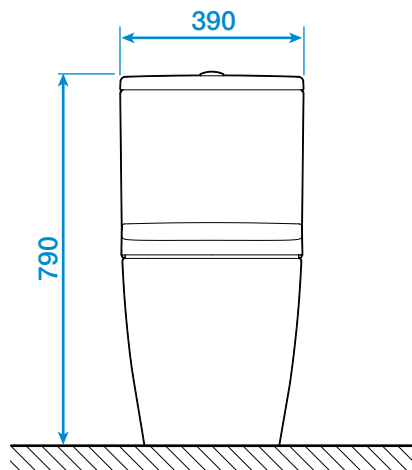
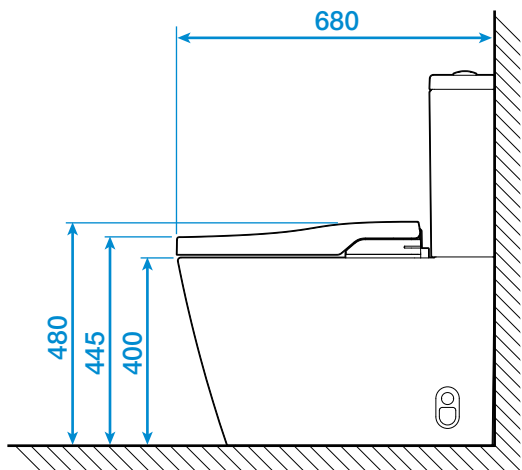

Alternative Anschlussoptionen für den Ablauf
Alternative drainage connection
Collegamenti di evacuazione alternativi
Alternative drainage connection

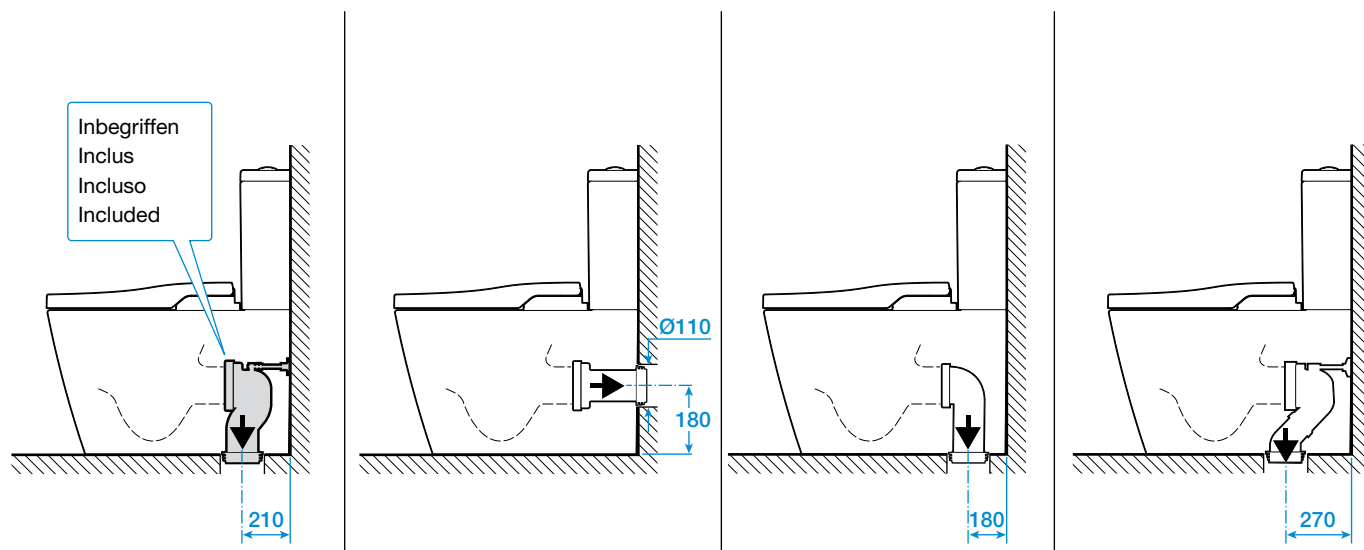

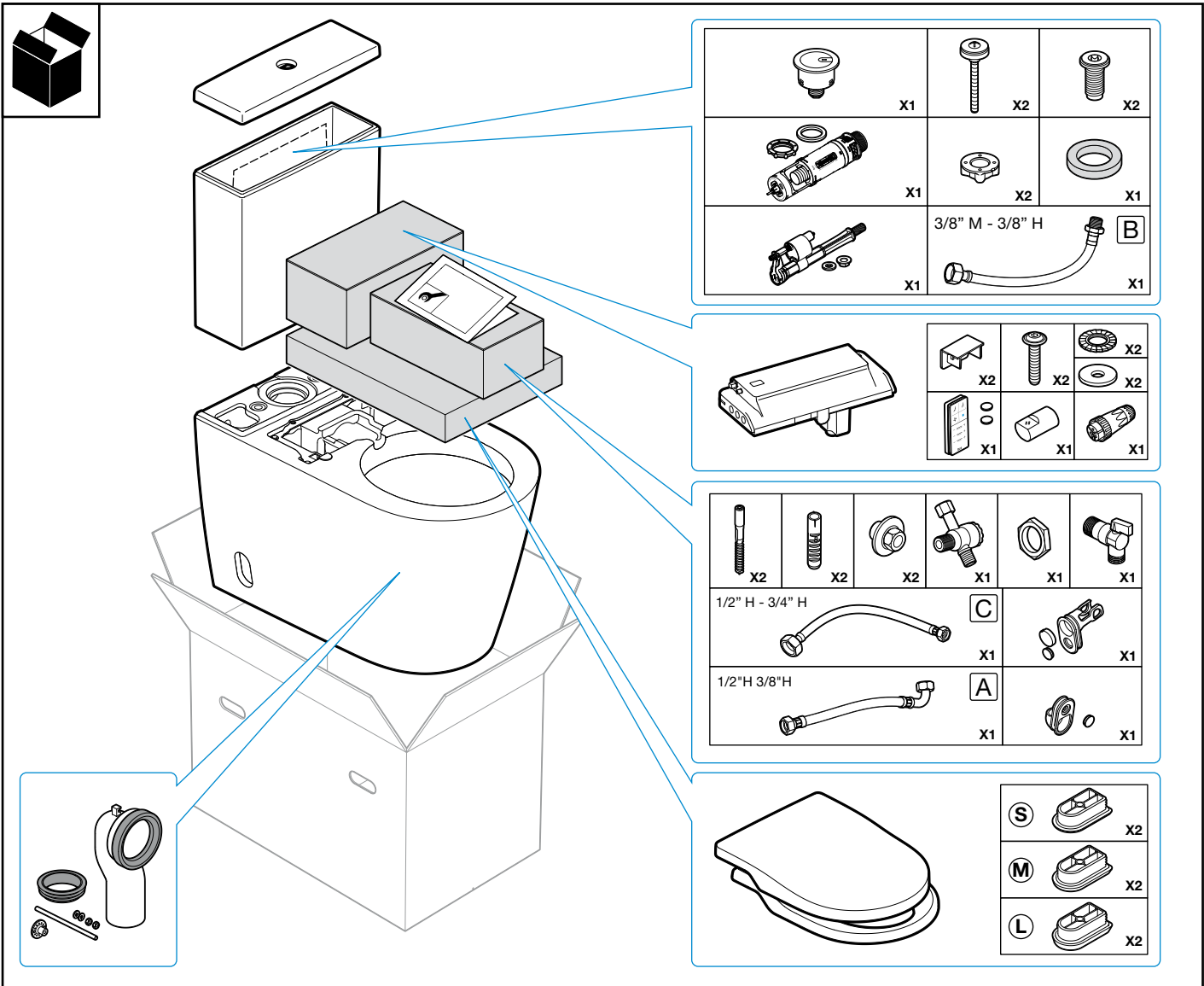
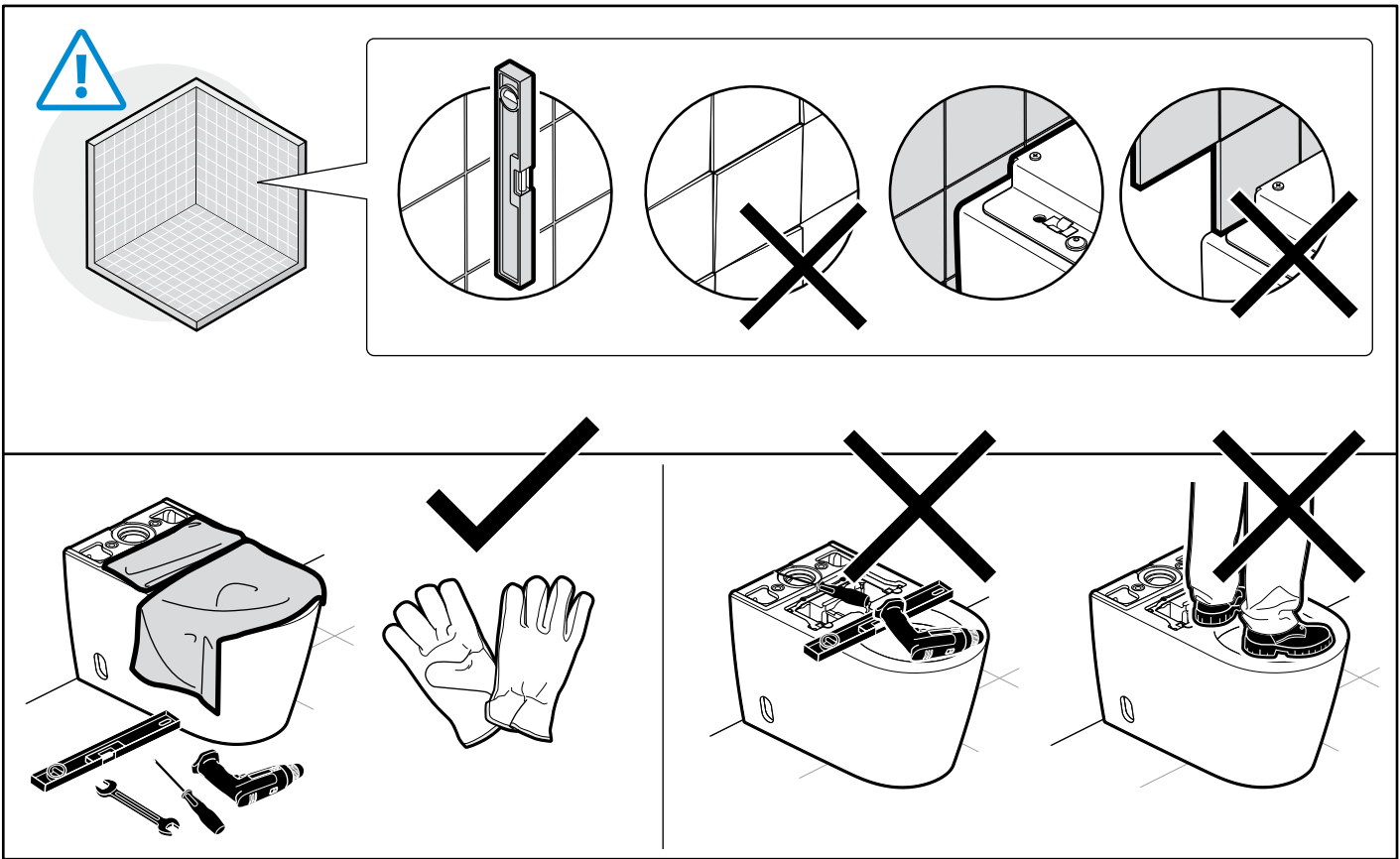

1

Wasseranschluss
Raccordement en eau

Collegamento idraulico
Pipes

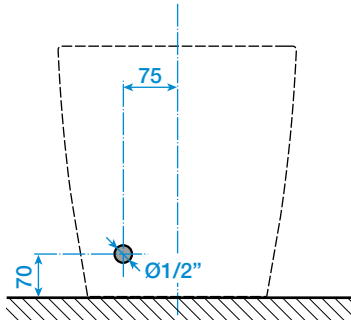

Option
Option
Opzione
Option

1a

Option
Option
Opzione
Option

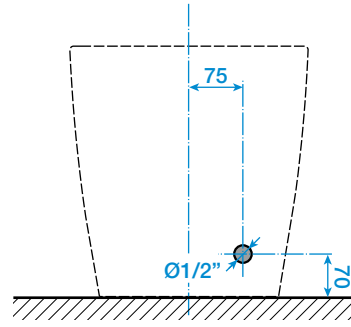
1b**2**

Stromanschluss
Raccordement électrique

Collegamento elettrico
Electrical

Option
Option
Opzione
Option

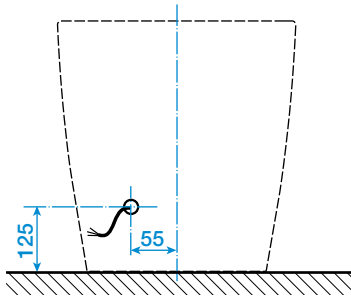
2a

Option
Option
Opzione
Option

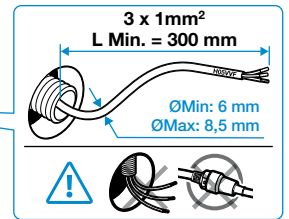
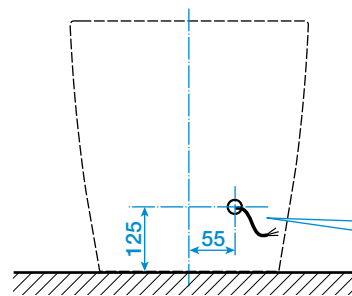
2b



A

Gemäß geltender Norm
 Selon les normes en vigueur
 Secondo la normativa vigente
 According to current legislation

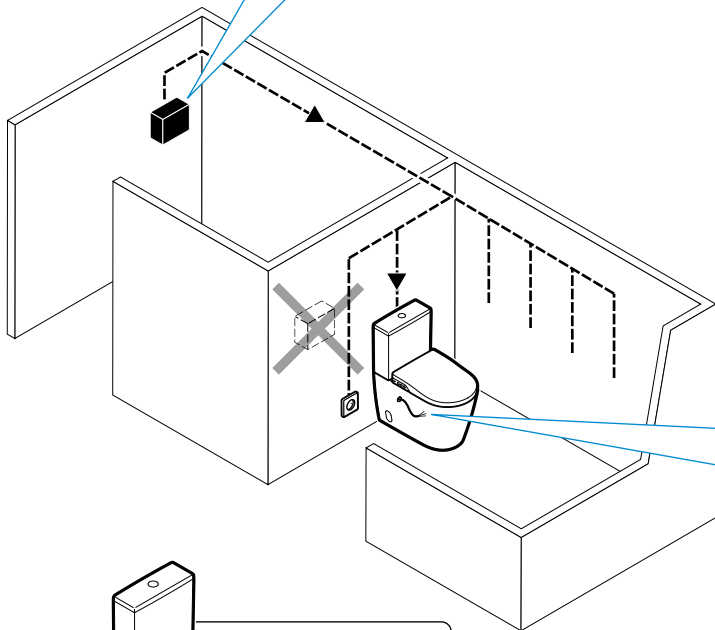
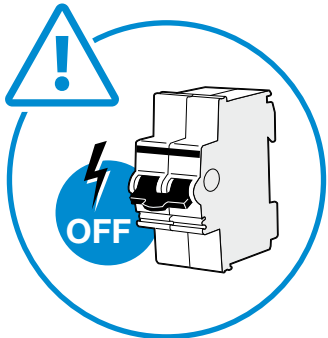

C

3 x 1mm²
 L Min. = 300 mm

ØMin: 6 mm
 ØMax: 8,5 mm

Vorgeschrieben
 Obligatoire
 Obbligatorio
 Mandatory

B

D

220-240 VAC
 50/60 Hz.
 1700 W Max.

CE

Dieses elektrische Produkt kann im Bereich 2 installiert werden, dabei muss jedoch die Wandsteckdose immer im Bereich 3 installiert werden.
 Diese Empfehlungen sind gültig, solange sie mit den jeweiligen Landesvorschriften übereinstimmen.
 Dieses Produkt (IPX4) darf keinem Wasserstrahl zwecks Reinigung ausgesetzt werden.

Ce WC électrique peut être installé en zone 2 mais la prise électrique doit toujours être installée en zone 3. Cette recommandation est valide si l'installation est compatible avec les réglementations en vigueur dans le pays. Ce produit (IPX4) ne doit pas être exposé à des jets d'eau pour son nettoyage.

Questo vaso elettrico può essere installato nella zona 2, anche se nel caso in cui venisse collegato mediante presa elettrica deve essere sempre installato nella zona 3. Questa raccomandazione è valida se consentita dalla normativa vigente nel Paese. Questo prodotto (IPX4) non deve essere esposto a getti d'acqua durante la pulizia.

This electric toilet may be installed in zone 2, although if connected to a wall-socket, it shall always be installed in zone 3.
 These recommendations are valid as long as the installation is compatible with the country regulations.
 This product (IPX4) shall not be exposed to water jets for cleaning purposes.

V = Bereich
 Volume
 Volume
 Volume

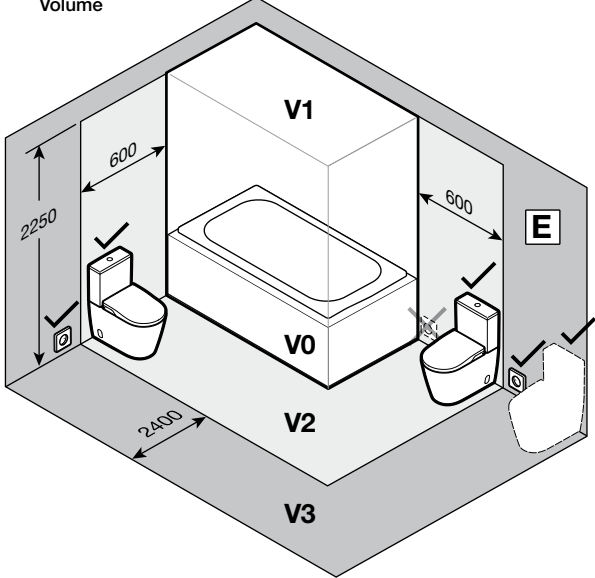

DE

- A** Die elektrische Anlage ist mit einem Fehlerstromschutzschalter mit $I\Delta N = 0,03$ A und 25 A Leistung und einem Leitungsschutzschalter mit 10 oder 15 A zu schützen, die außerhalb des Badezimmers installiert sein müssen.
- B** Dieses Produkt ist direkt an eine feste Installation anzuschließen. Verlängerungsstecker sind nicht zulässig.
- C** Für die Installation ist ein Netzkabel mit drei Leitern (Phase, Neutralleiter, Schutzleiter) mit mindestens 1 mm^2 Querschnitt zu verwenden, das ausschließlich für das WC bestimmt ist. Das Stromanschlusskabel des Dusch-WCs darf bei Beschädigung nur durch den Kundendienst repariert oder ausgetauscht werden.
- D** Die Betriebsspannung für das WC muss 220-240 V, 50/60 Hz betragen.
- E** Elektrische Anschlüsse des WCs dürfen nicht abgeändert werden.

Es dürfen keine elektrischen Geräte in das WC eingeführt werden.

Die Installation ist von qualifiziertem Fachpersonal gemäß den geltenden nationalen Vorschriften vorzunehmen.

FR

- A** L'installation électrique doit être protégée par un interrupteur différentiel $I\Delta n$ 0.03A et 25 A et un interrupteur magnétothermique de 10 ou 15A, situés en dehors de la salle de bains.
- B** La connexion en alimentation de ce produit doit être connectée de manière permanente à une installation électrique fixe. Le branchement sur une multiprise n'est pas acceptable.
- C** La ligne électrique à installer doit être un tuyau composé de trois conducteurs (phase, neutre, terre) d'au moins 1 mm^2 de section exclusivement dédiée au WC. Dans le cas où, en raison d'une défaillance, il est nécessaire de manipuler ou de remplacer le câble d'alimentation, cela ne doit être effectué que par le Service Technique.
- D** L'intervalle de fonctionnement de ce WC est de 220-240V, 50/60Hz.
- E** Aucun composant ni connexion électrique de ce WC doit être manipulé.

Aucun appareil électrique ne doit être introduit à l'intérieur du WC.

Ce produit doit être installé par du personnel qualifié, en accord avec les normes nationales en vigueur.

IT

- A** L'installazione elettrica deve essere protetta da un interruttore differenziale $I\Delta n$ 0,03 A e di potenza 25A ed un interruttore differenziale $I\Delta n$ 0,03 A e di potenza 25A ed un interruttore magnetotermico da 10 o 15A.
- B** Il collegamento di alimentazione deve essere sempre eseguito utilizzando il connettore fornito, con un collegamento fisso o una presa a muro.
- C** I fili elettrici devono convogliare in un tubo a tre conduttori senza soluzione di continuità (fase, neutro, terra) $3 \times 1\text{ mm}^2$ per uso esclusivo. In casi di guasti della connessione elettrica la stessa deve essere ripristinata da personale qualificato.
- D** Il range di funzionamento del prodotto è di 220-240V, 50/60Hz.
- E** Non si deve manipolare nessun collegamento elettrico del vaso.

Non si deve aggiungere all'interno del wc nessuna componente elettrica.

L'installazione deve essere effettuata da personale qualificato, secondo le normative vigenti.

EN

- A** The electrical installation must be protected by means of a $I\Delta n$ 0,03A and 25A differential switch and a magnetothermal switch of 10 or 15A. Both switches must be placed outside the bathroom.
- B** The power connection of this product must be permanently connected to a fixed electricity line. Placement of a plug is not acceptable.
- C** The electrical line to be installed must be a hose consisting on three drivers (phase, neutral, earth) of at least 1 mm^2 of section exclusively dedicated to the WC. In the event that, due to failure, it is necessary to handle or replace the power cable, this must only be done by Technical Service staff.
- D** The range of function of the WC is 220-240V, 50/60Hz.
- E** Neither component nor connection of the WC must be operated.

No electrical device must be introduced inside the WC.

This product must be installed by qualified personnel, in according with the national current regulation.

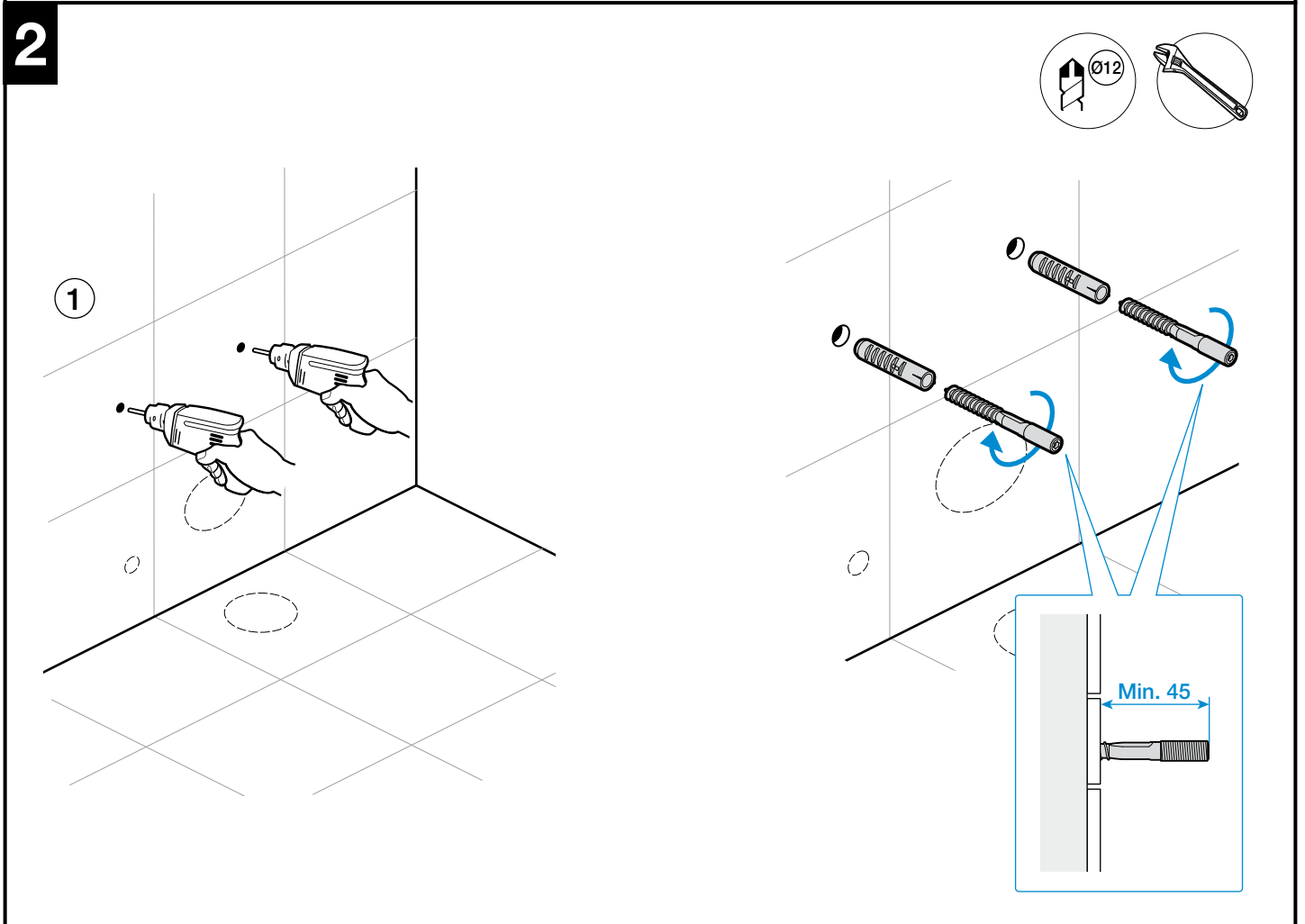
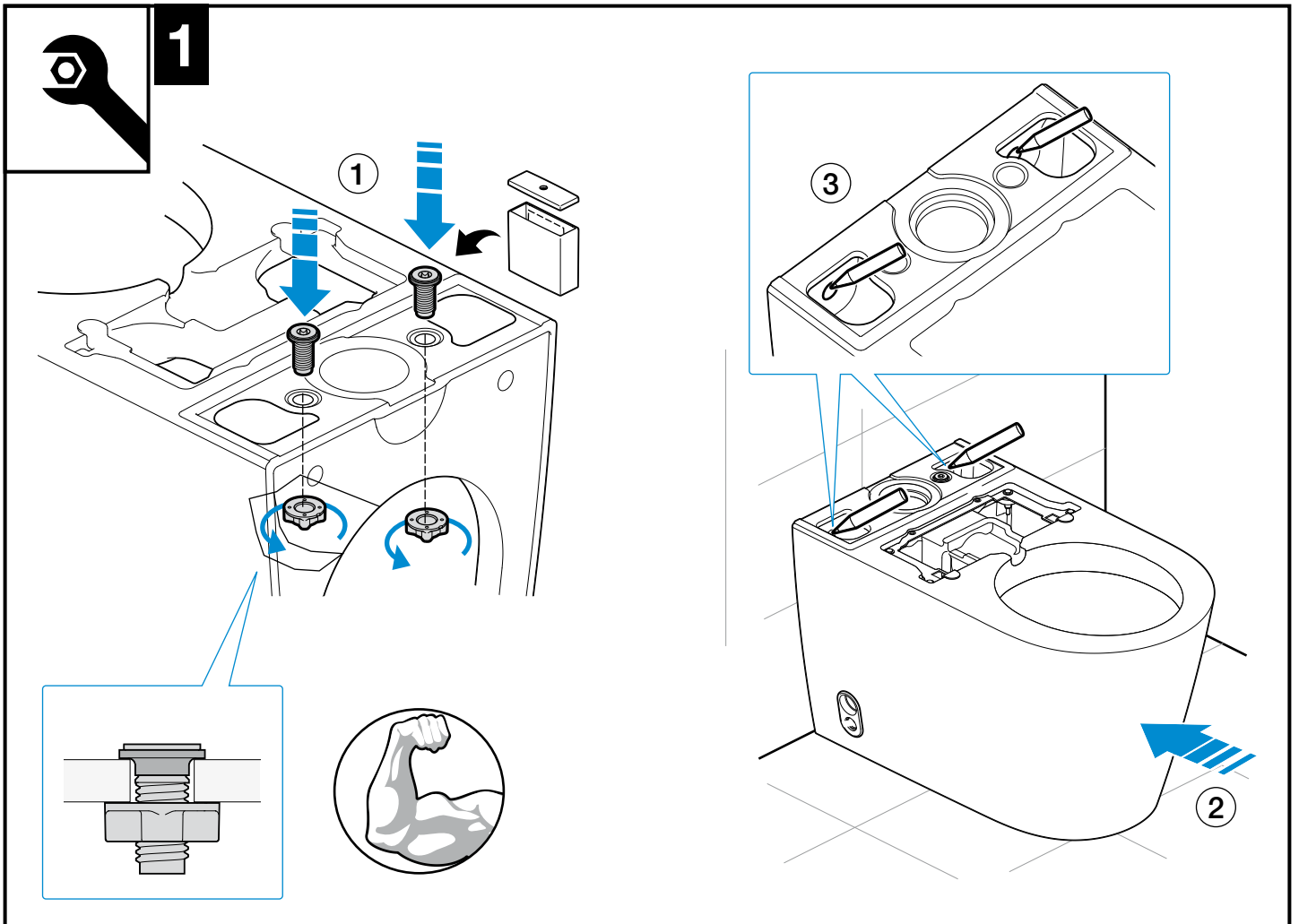

3

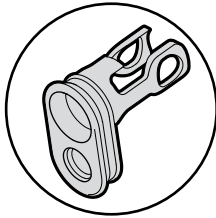

Halterung für den Wasserfilter
Support filtre à eau
Supporto del filtro dell'acqua
Water filter support

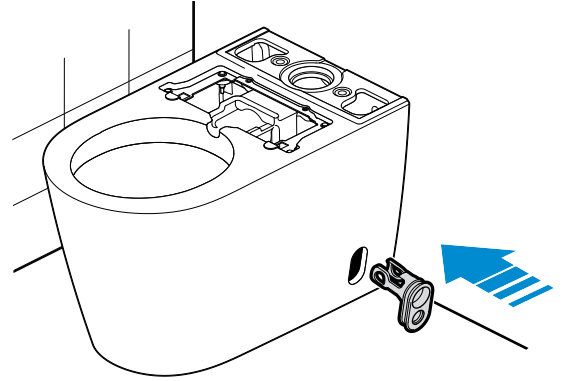
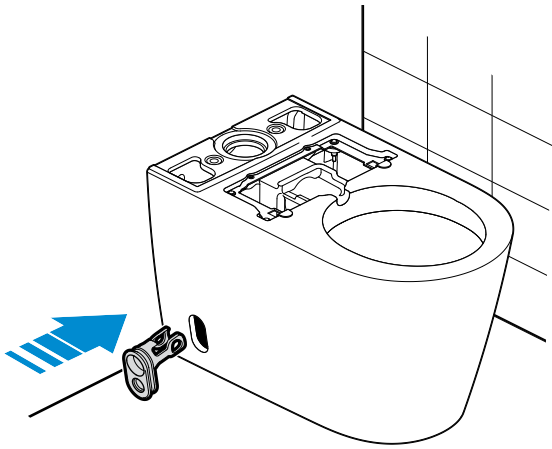

Installieren Sie den Wasserfilter auf der Seite die nach Montage am besten zugänglich ist
Installer le filtre à eau du côté le plus accessible
Installare il filtro sul lato con l'accesso più facile
Install the water filter on the most accessible side

4

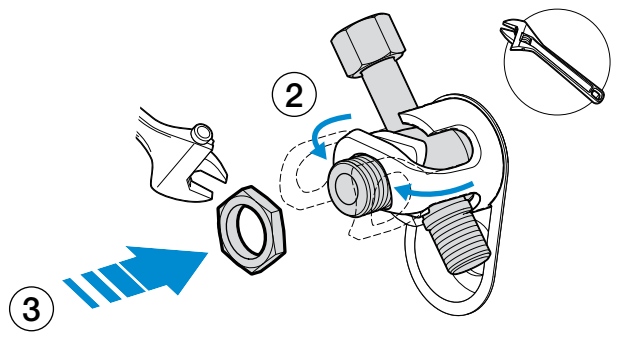
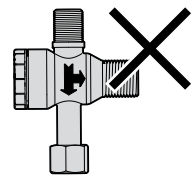
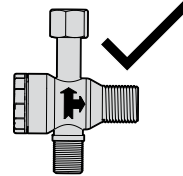
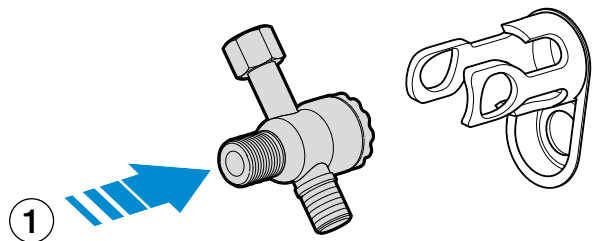
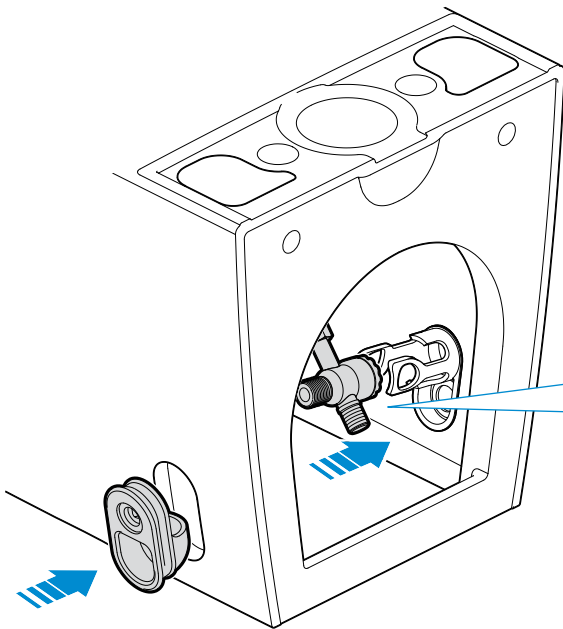

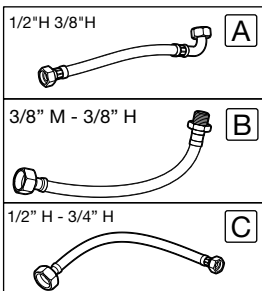
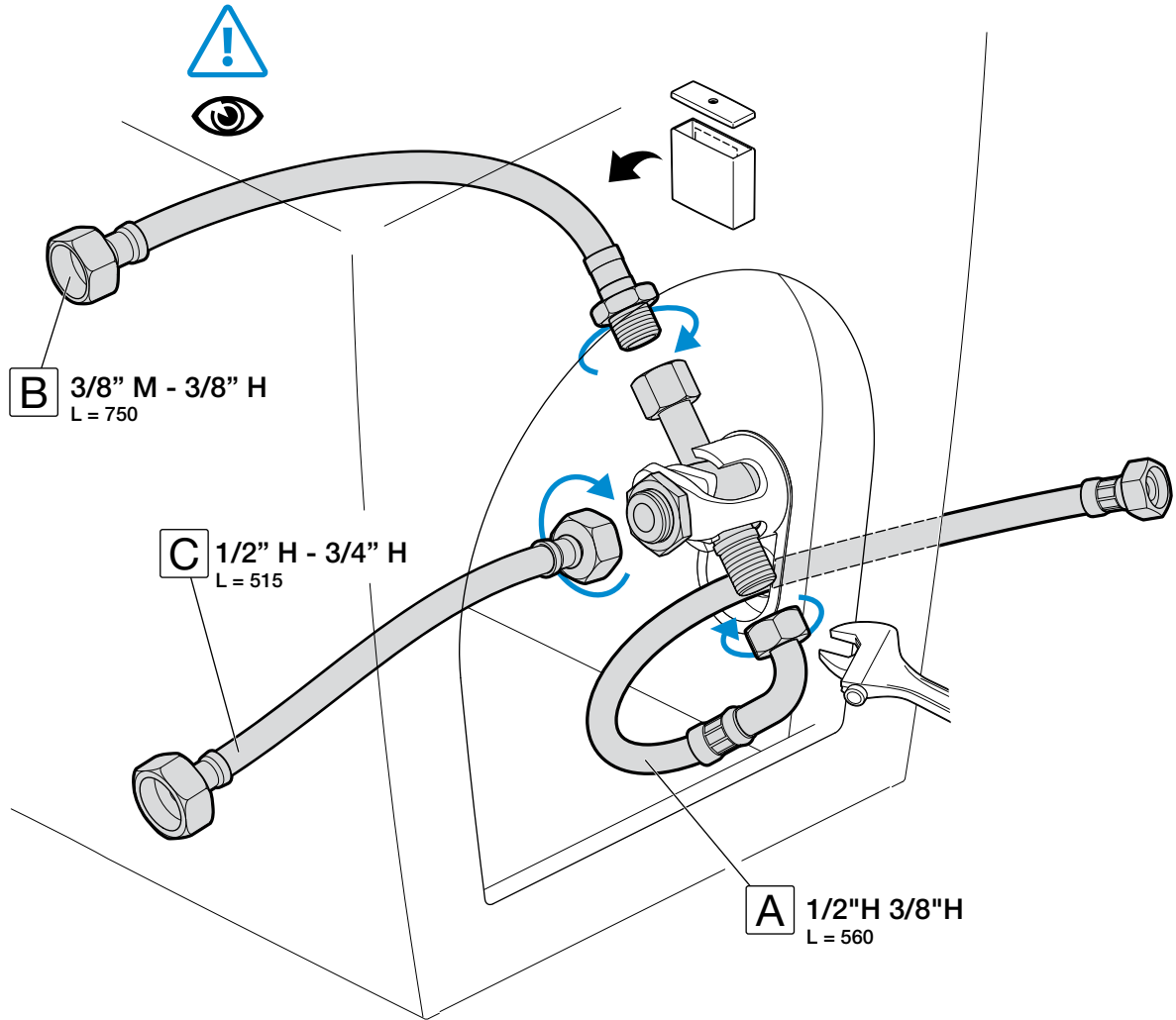

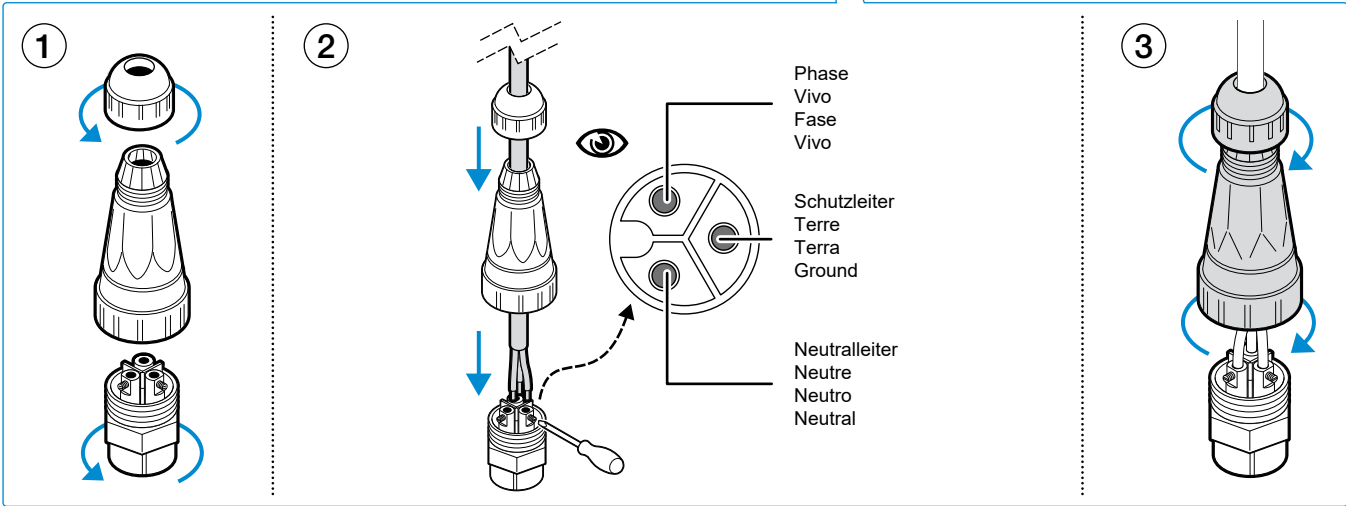
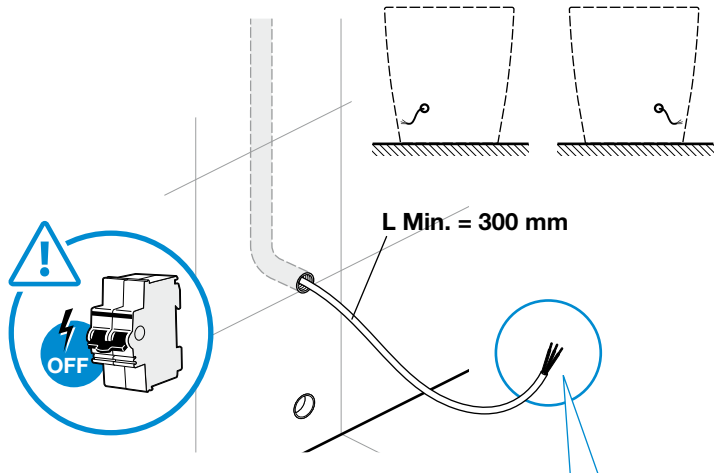
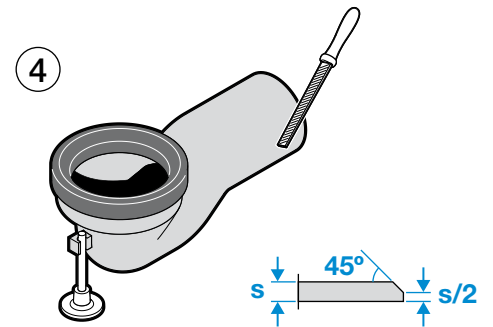
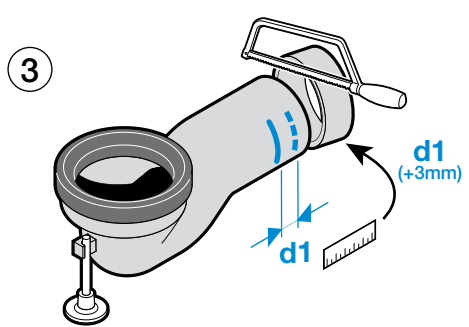
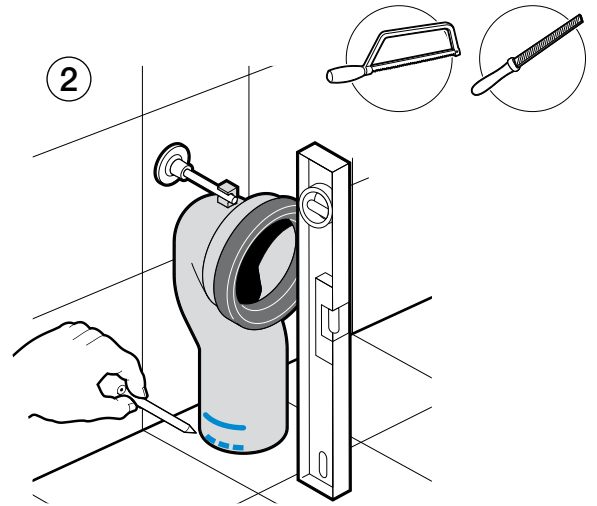
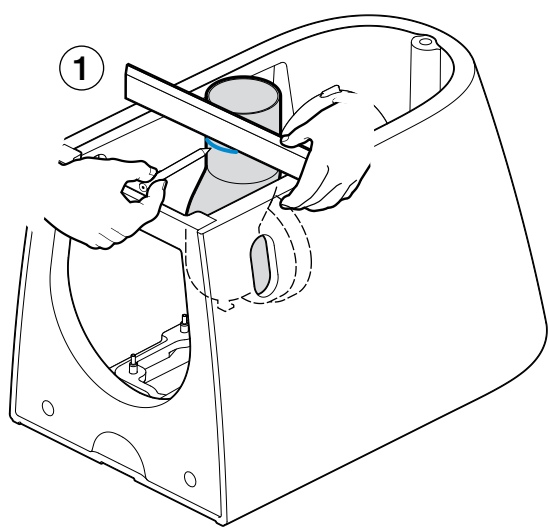
6**7**

9

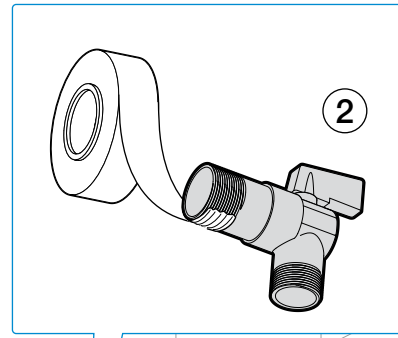
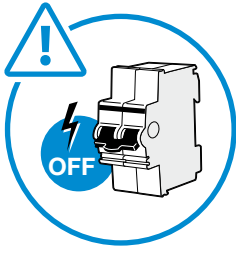

2

1

Option
Option
Opzione
Option

1a

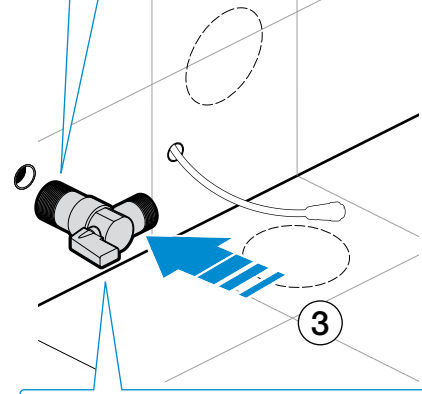
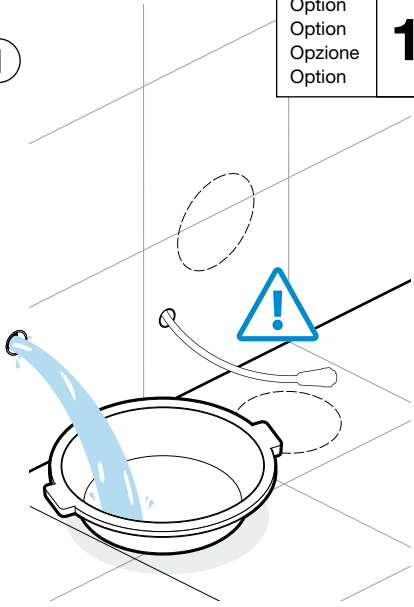

3

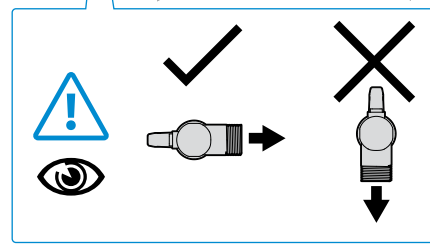

10

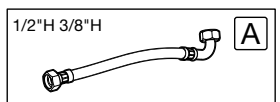
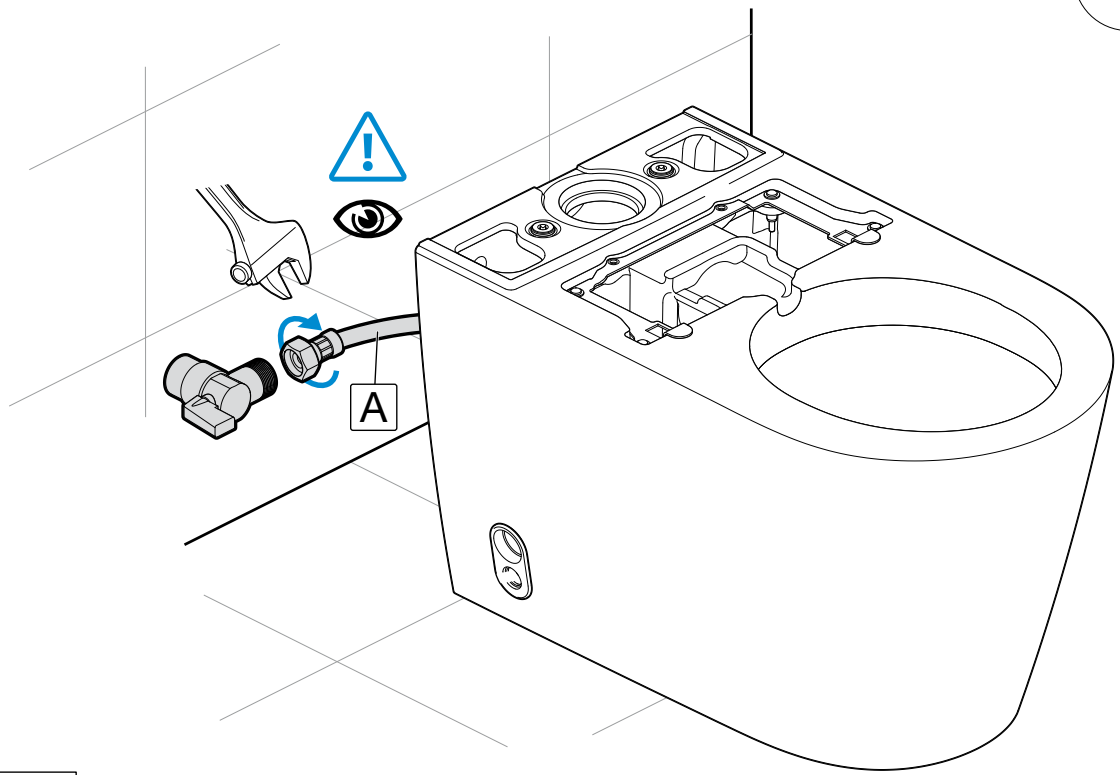

11

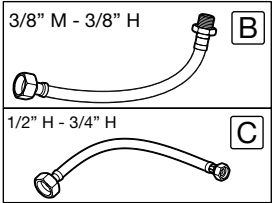
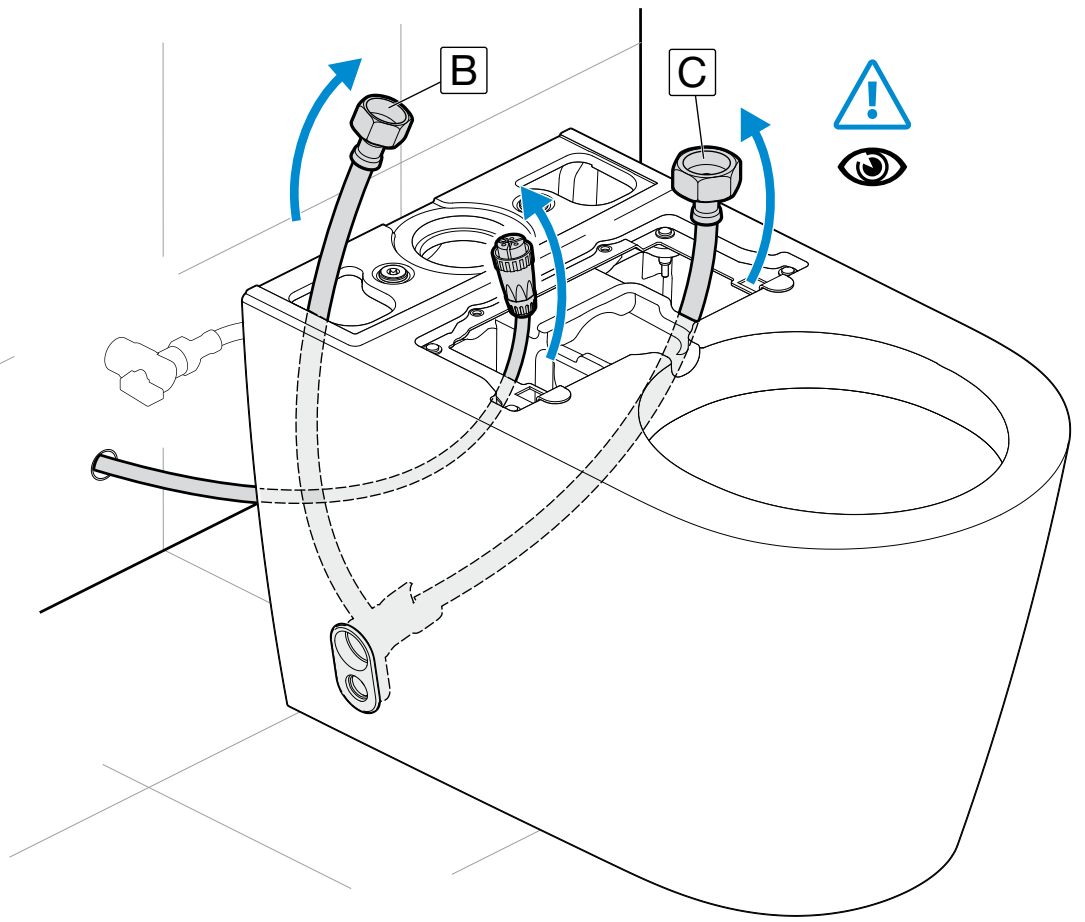

12

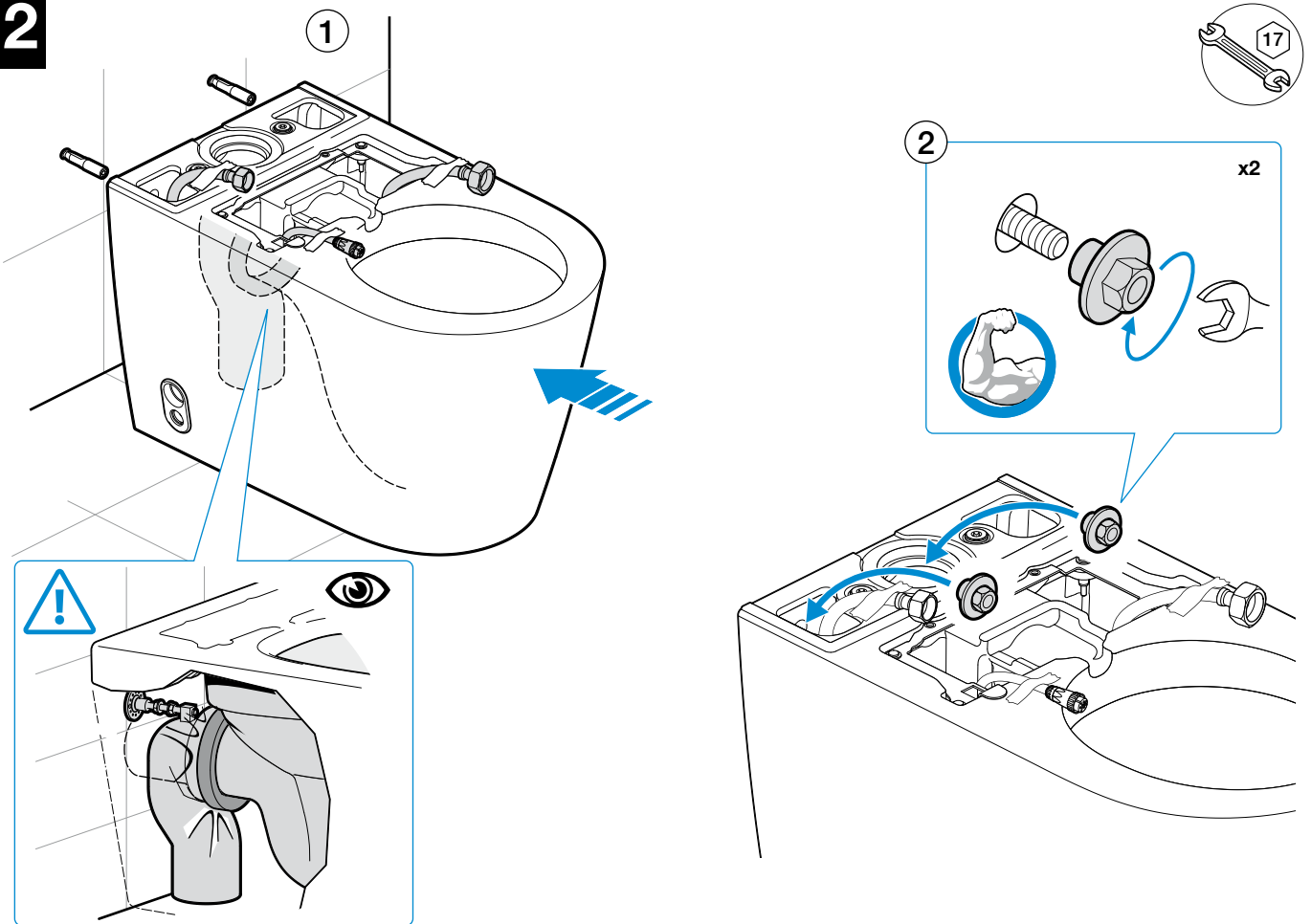

13

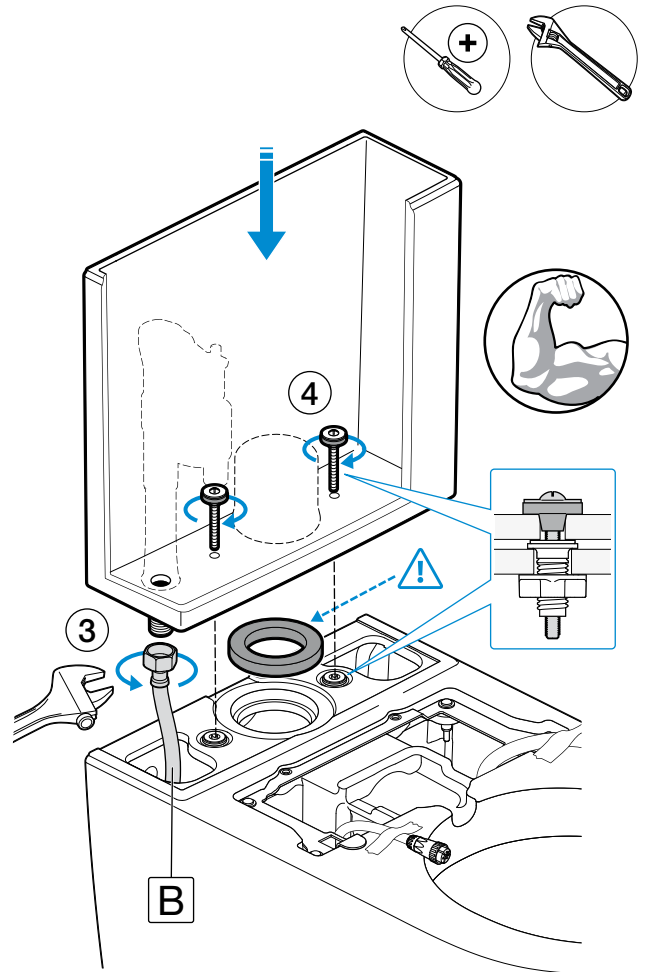
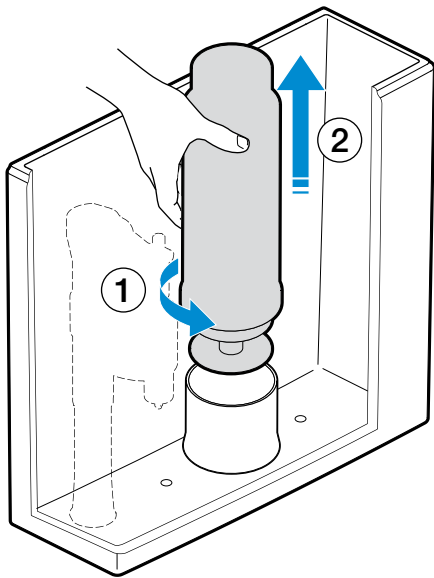

14

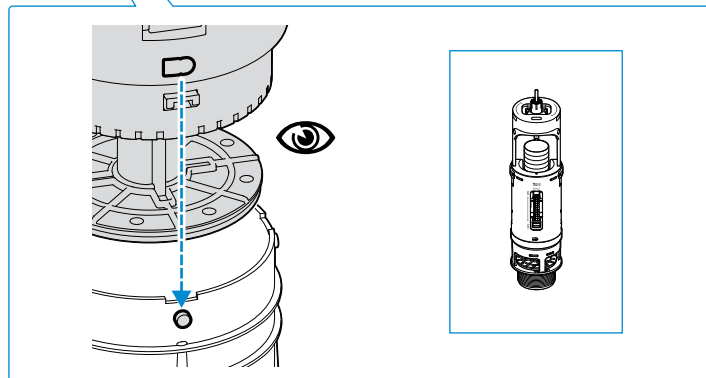
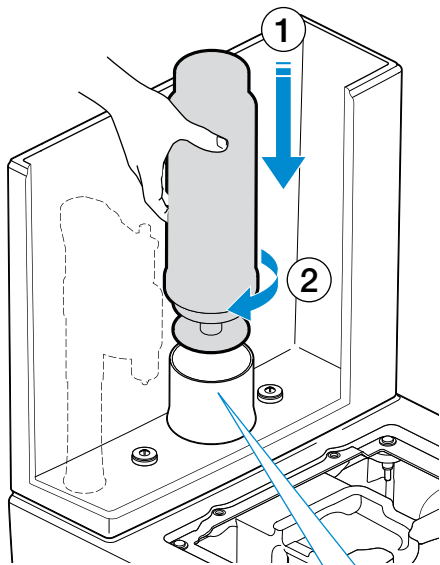

15

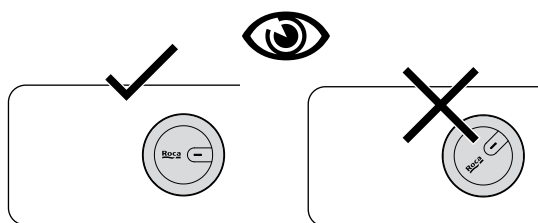
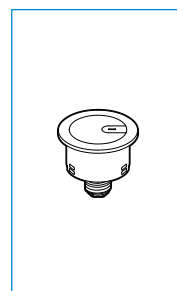
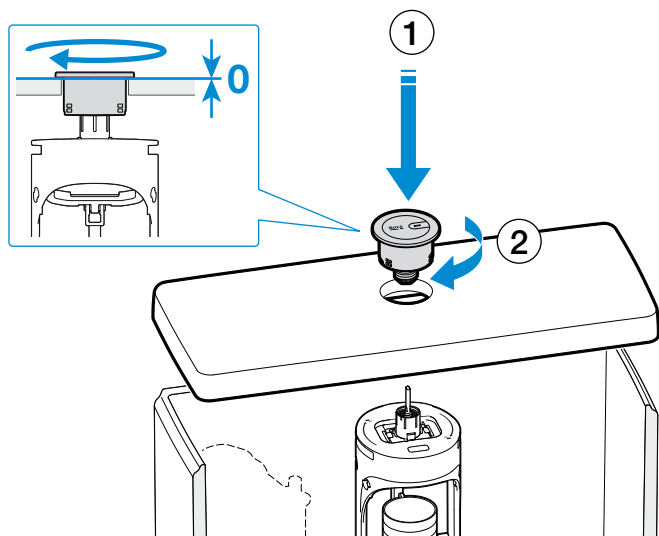

16

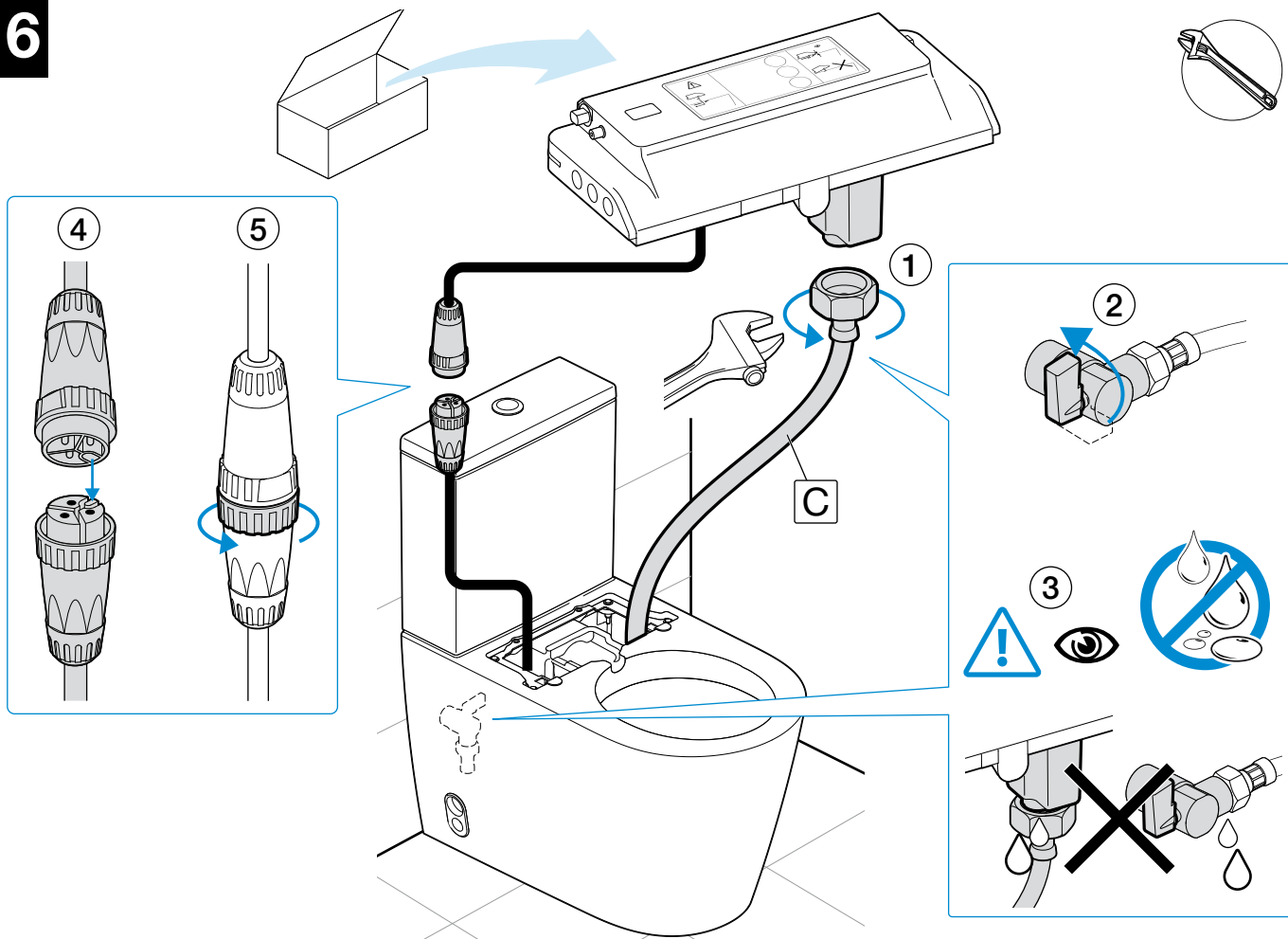

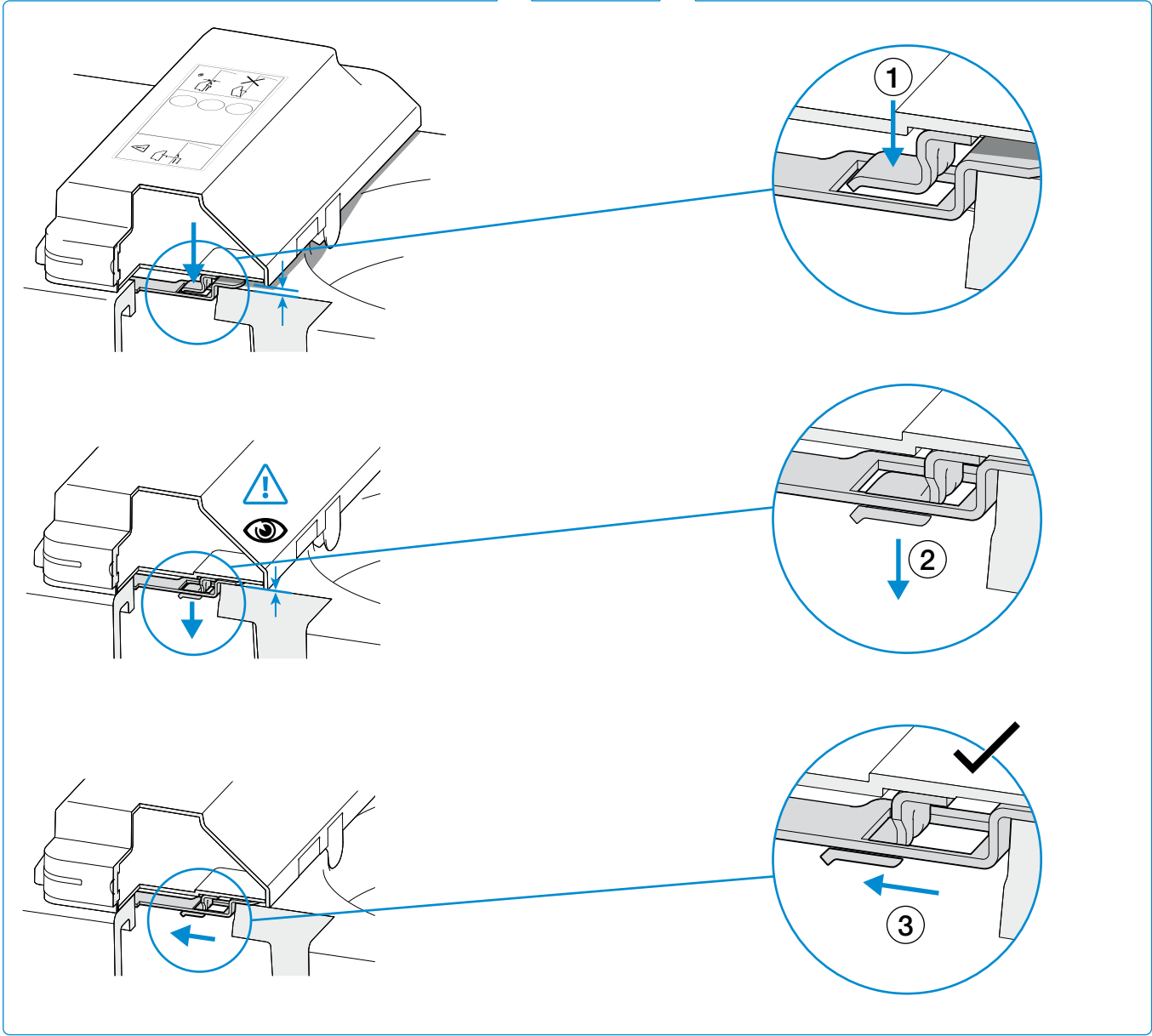
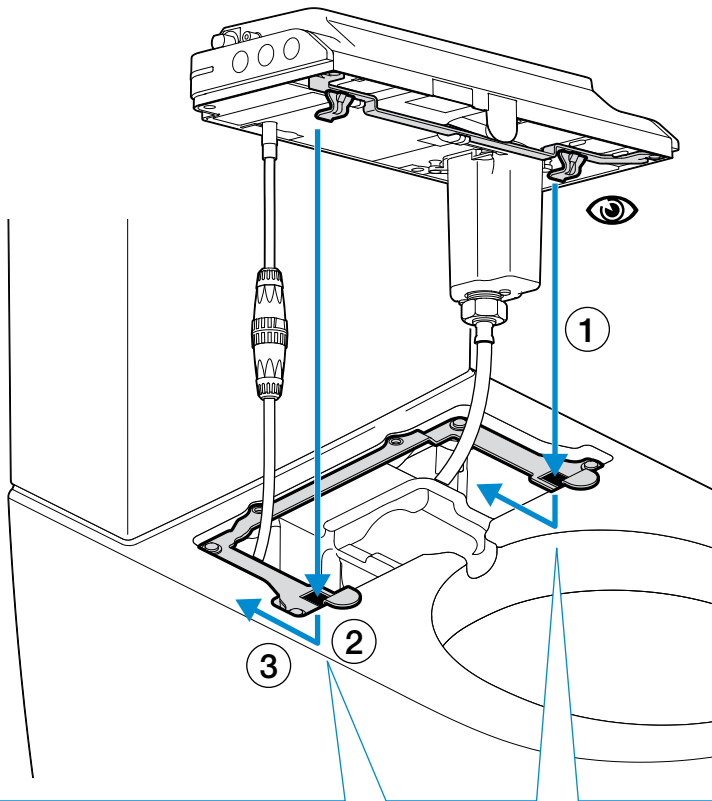

18

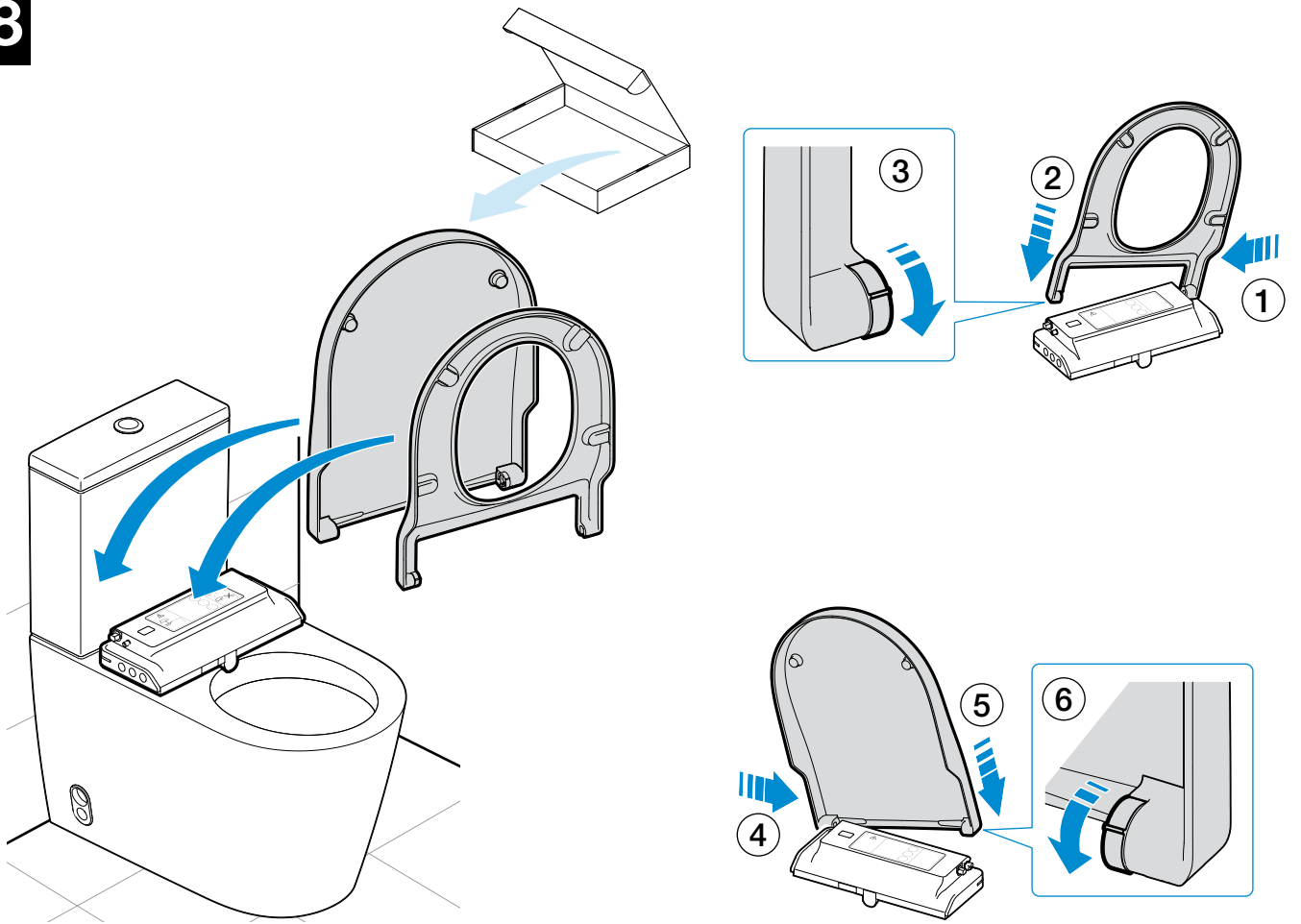

19

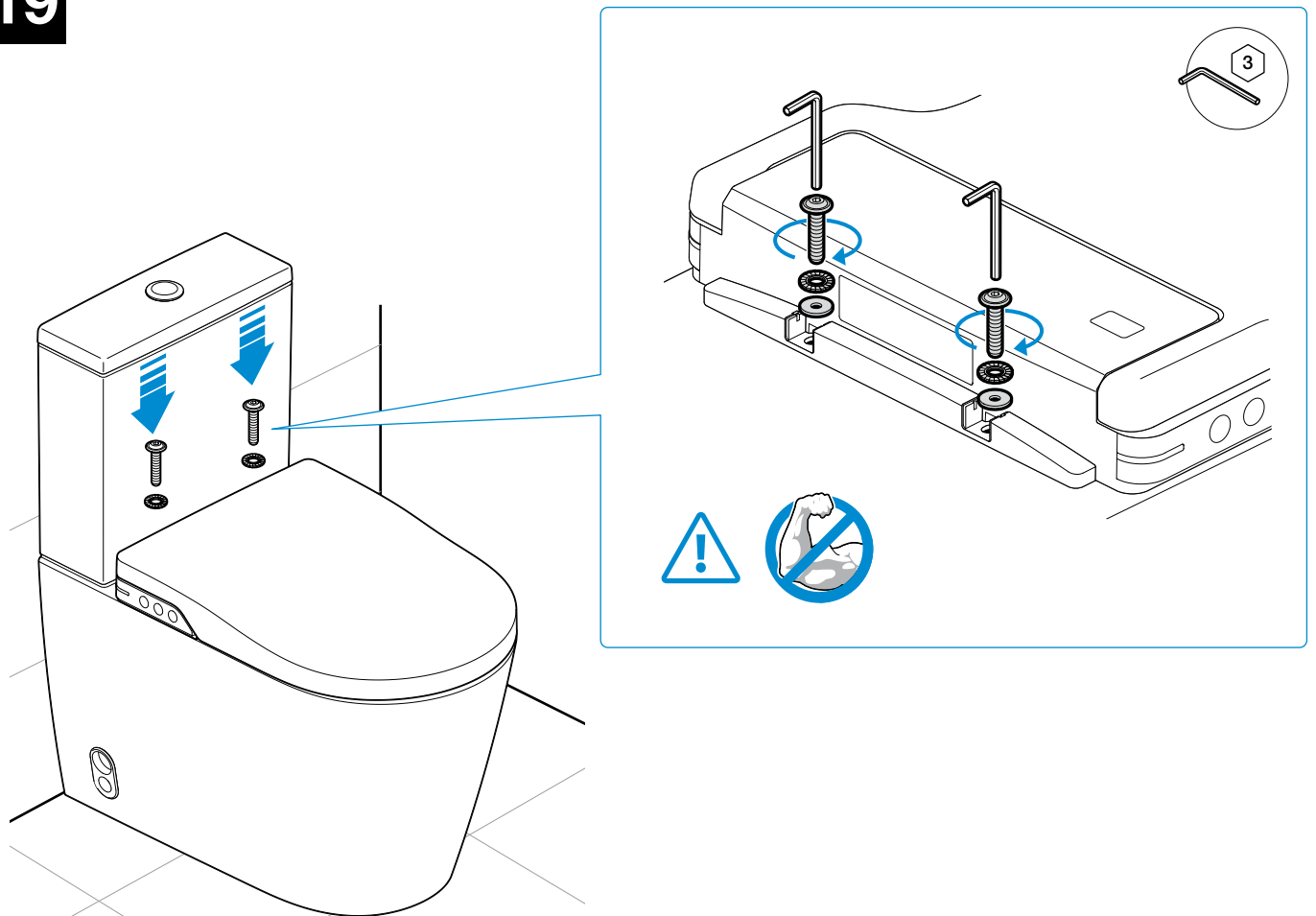

20

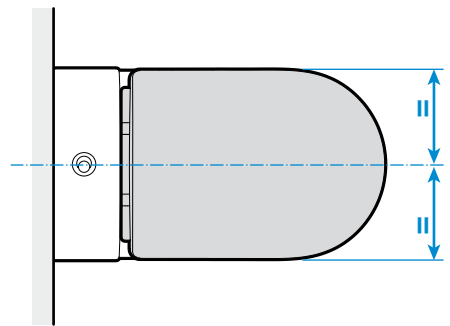
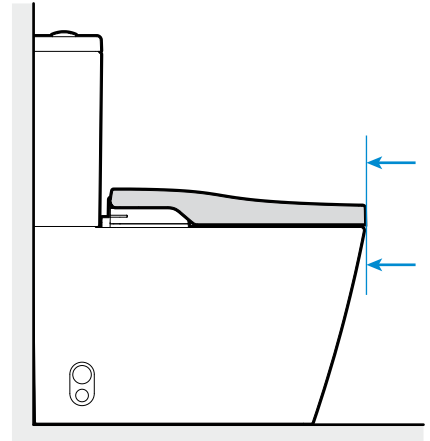
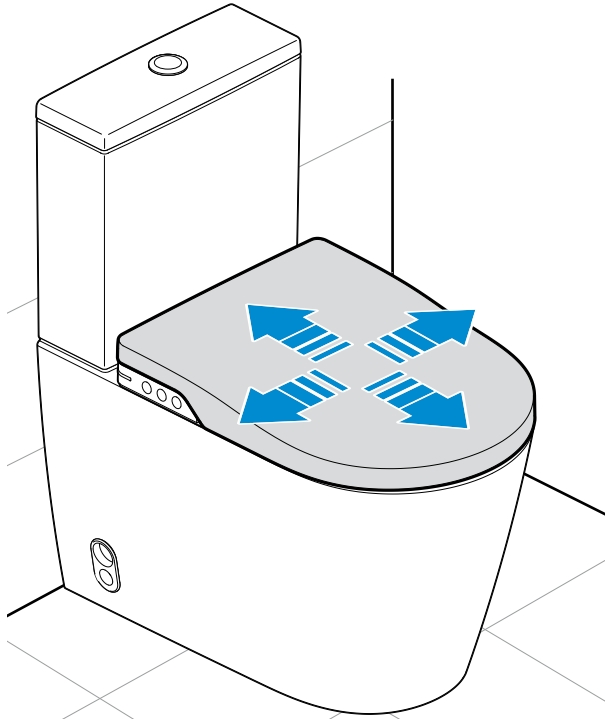

21

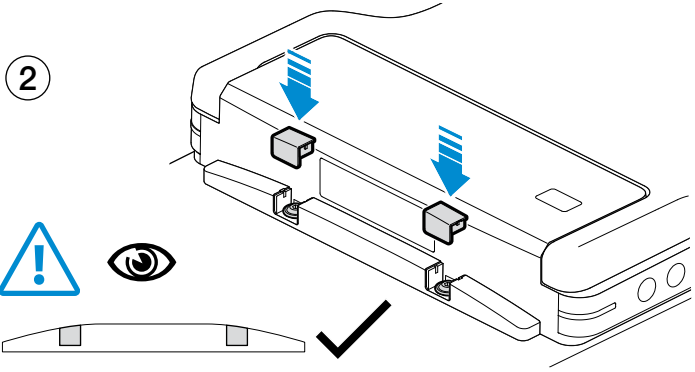
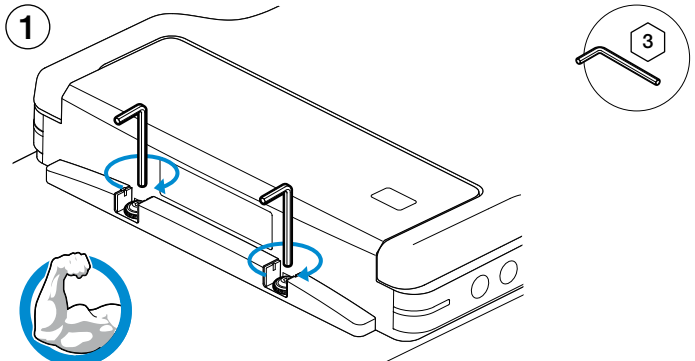
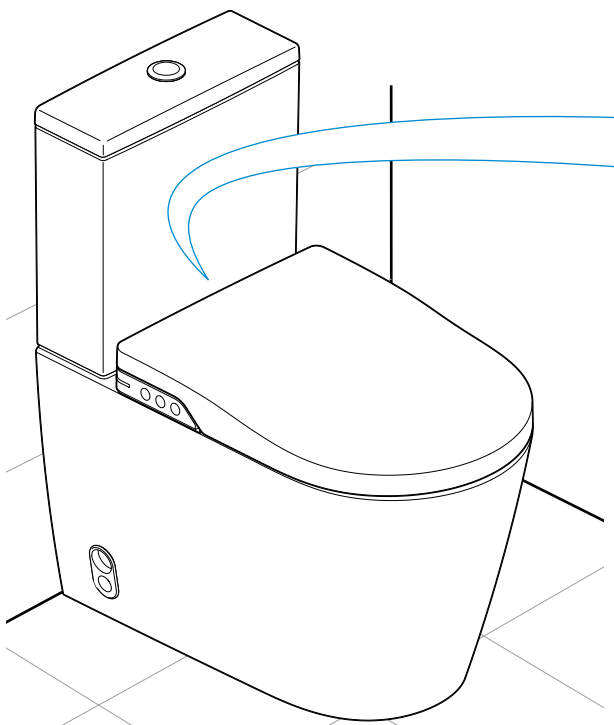

22

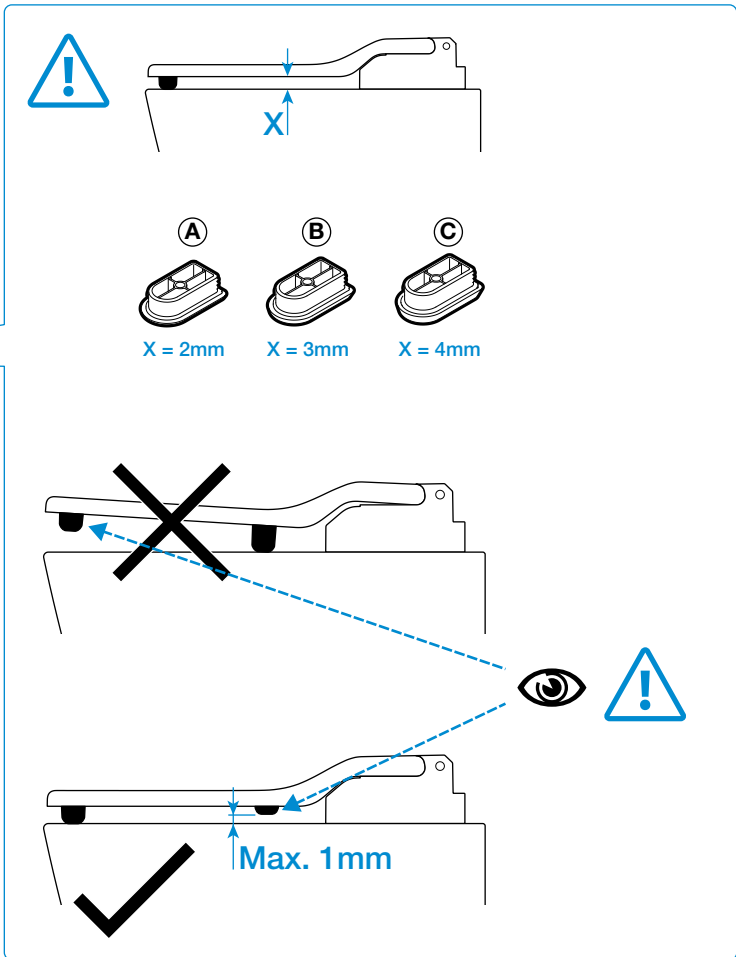
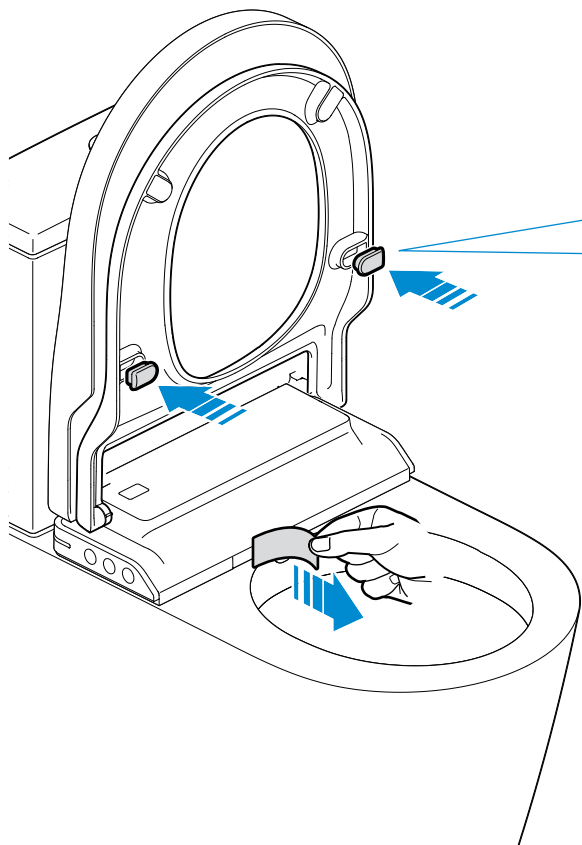

23

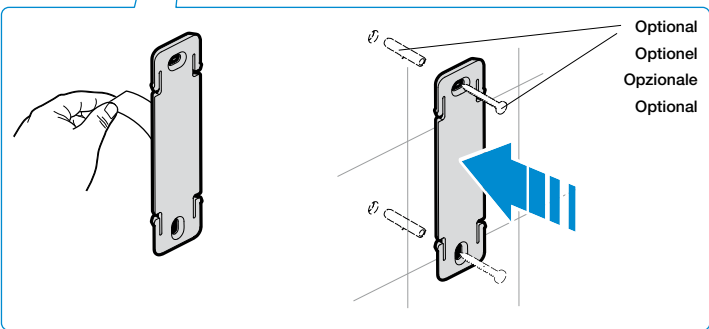
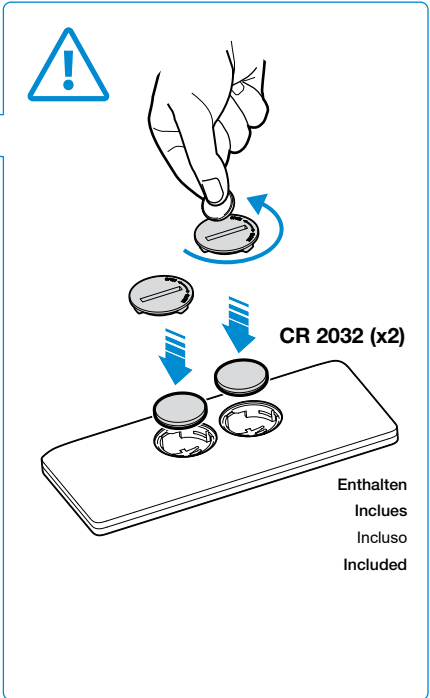
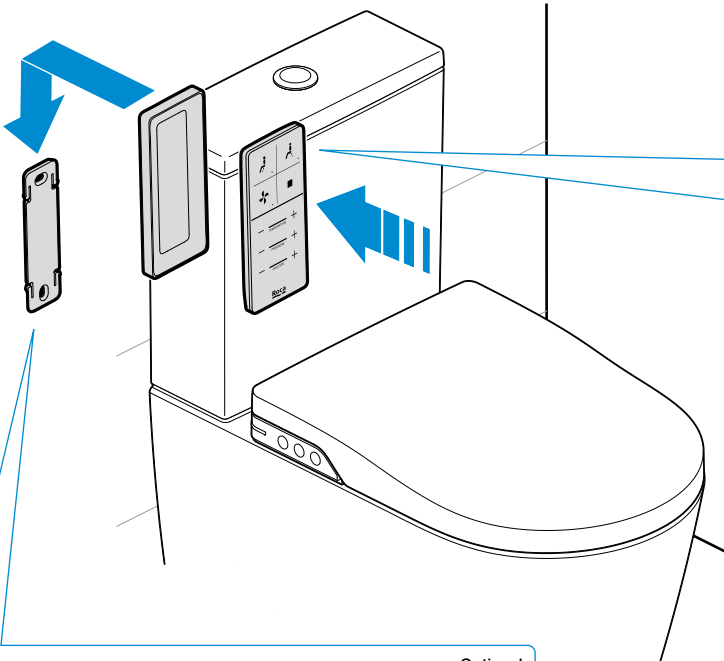

24

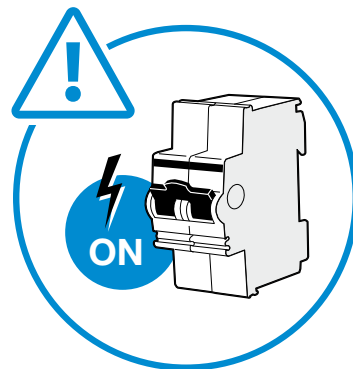
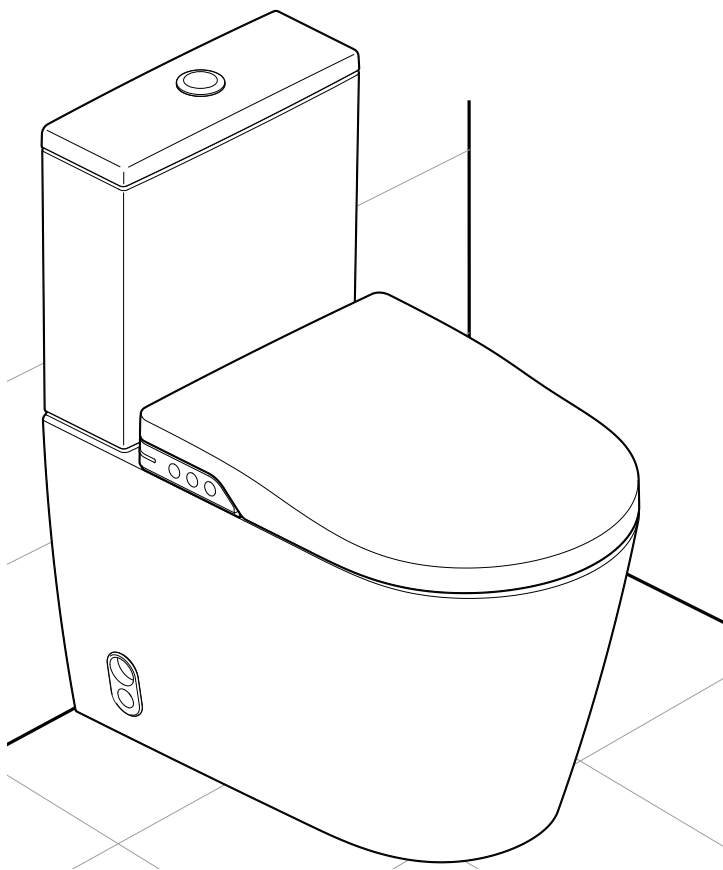

25

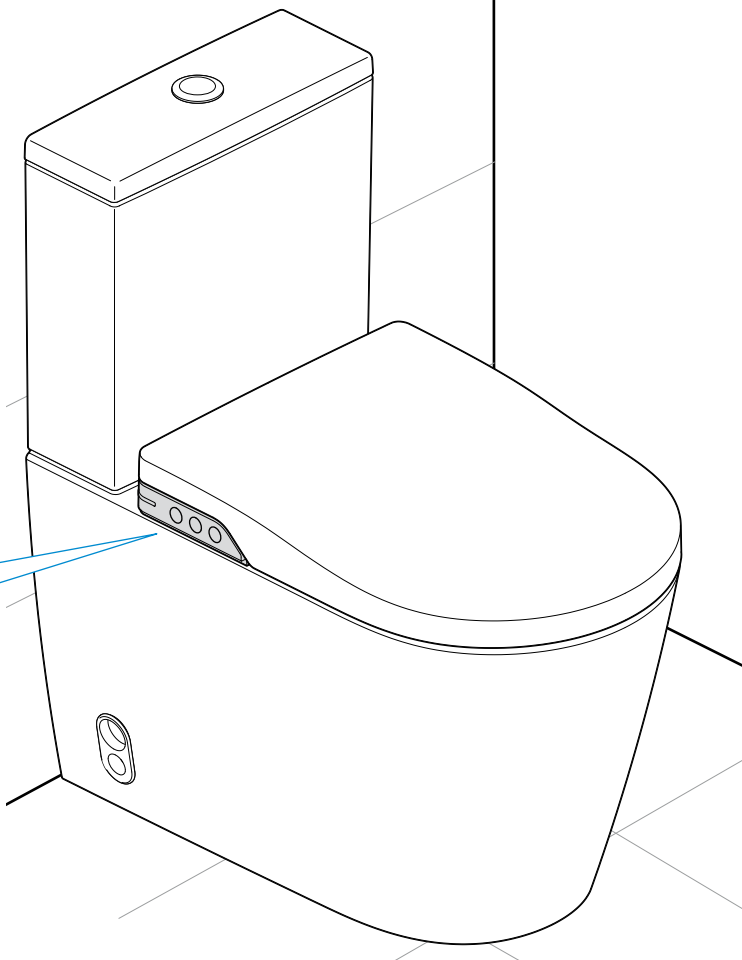

Siehe Gebrauchsanleitung
Voir le manuel d'utilisation
Vedere manuale utente
See user manual



Roca Sanitario, S.A.
Avda. Diagonal, 513
08029 Barcelona
SPAIN
www.roca.com



productsupport.rs@roca.net
soporteproducto.rs@roca.net